

CONTROLLER SERIES CRC140

ESBE series CRC140 is a combined weather compensating and return temperature controller with integrated actuator made especially for applications with a heat circuit, 4-way valve and boiler without storage tank.

OPERATION

The ESBE series CRC140 is designed to provide a high level of comfort thanks to the possibility to set a perfect characteristic heating curve and at the same time protect the boiler circuit from too low or too high return temperature.

The controller consist of two parts:

- actuator unit to be mounted to the mixing valve controlling the heat supply, with 2 preassembled flow pipe sensors S1 and S2.
- outdoor sensor, to be mounted on the north side of the building.

The primary function is to keep the temperature in the heating circuit according to characteristic heating curve (sensor 1) by opening or closing the valve and at the same time supervising that the return temperature in the boiler circuit (sensor 2) is within the set temperature window. If the temperature at the boiler circuit falls outside the temperature window the controller will change mode and open or close the valve to get the temperature at sensor 2 back within the temperature window. In both modes the flow temperature at the heating circuit will never be below the set minimum flow temperature or above the set maximum flow temperature.

The heating circuit regulation is based on outdoor sensor feedback and an adjustable characteristic heating curve. An offset / parallel adjustment of the characteristic heating curve may be activated by an external signal for example night settings. For applications with well insulated building and quick heating systems such as radiator circuit a temperature filter can be activated to delay an outdoor temperature change to avoid an imbalance between estimated and actual heating demand .

MOUNTING

Power supply by 230 V AC adapter (complete with transformer, cable and wall socket plug).

Flow pipe sensor S1 comes with 1.5m cable and flow pipe sensor S2 comes with 2m cable. All sensors must be carefully insulated from the ambient temperature.

Outdoor sensor with 20 m cable. The sensor shall be mounted on the north side of the building under the eaves in order to protect the sensor from direct sunlight and rain.

Thanks to the special interface between the controller series CRC140 and the ESBE series VRG, VRH and VRB, the unit as a whole has a unique stability and precision when regulating. The controller series CRC140 is also easily mounted in ESBE valves MG, G, F and BIV.



CRC141
230 V AC

SUITABLE MIXING VALVES

- Series VRG100
- Series VRG200
- Series VRG300
- Series VRH100
- Series VRB100
- Series MG*
- Series G
- Series F ≤ DN50
- Series BIV
- Series T and TM
- Series H and HG

* Not 5MG

OPTIONAL EQUIPMENT

Art. No.

17055900 _____ CRB915 GSM-module

16200700 _____ ARA801 Auxiliary switch kit

ADAPTOR KITS

Required adaptor kits for easily fitting onto an ESBE rotary mixing valve is supplied with each actuator. Adaptor kits can also be ordered separately.

Art. No.

16000500 (= supplied with actuator)

_____ ESBE valve series VRG, VRH, VRB, G, MG, F, BIV, T, TM, H, HG

Adaptor kits for other mixing valves are available as follows:

Art. No.

16000600 _____ Meibes

16000700 _____ Watts

16000800 _____ Honeywell Corona

16000900 _____ Lovato

16001000 _____ PAW

TECHNICAL DATA

Ambient temperature: _____ max. +55°C

_____ min. -5°C

Sensors: _____ Temperature sensor type NTC

Temperature range,

Flow pipe sensor S1 and S2: _____ +5 to +95°C

Outdoor sensor: _____ -50 to +70°C

Enclosure rating: _____ IP41

Protection class: _____ II

Power supply: _____ 230 ± 10% V AC, 50 Hz

Power consumption - 230 V AC: _____ 10 VA

Torque: _____ 6 Nm

Running time at max. speed: _____ 30s

ErP Temperature controls class: _____ III

Energy efficiency contribution: _____ 1.5%

CE LVD 2014/35/EU
EMC 2014/30/EU
RoHS 2011/65/EU

CONTROLLERS

CONTROLLER SERIES CRC140

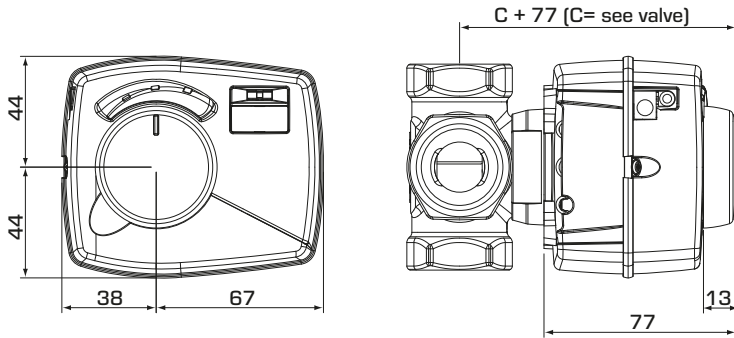

Installation dimensions for Controller Series
CRC140 with ESBE VRG100, VRG200,
VRG300, VRH100 and VRB100 mixing valves

SERIES CRC140

Art. No.	Reference	Voltage [V AC]	Torque [Nm]	Weight [kg]	Note
12824100	CRC141	230	6	1.0	

INSTALLATION EXAMPLES

