

C 230 EVO-...

FLOOR STANDING GAS CONDENSING BOILER



C 230 EVO-...

• C 230 EVO-85 to 210

from 18 to 217 kW, range of gas condensing boilers for heating and DHW production via independent DHW tank



Heating



Domestic hot water via independent tank



Aluminium Silicon



Natural gas / Propane



Smart TC compatible



Condensation



Hydrogen

20%

OPERATING CONDITIONS

Max. operating temperature: 90 °C
Safety temperature limiter: 110 °C
Max. operating pressure: 6 bar
Min. operating pressure: 0.8 bar
Power supply: 230 V/50 Hz

homologations

B23P - C13 - C53 - C63 - C93

Gas family: For natural gas and propane. The device complies with natural gas containing up to 20% hydrogen (H2).

NOx class: 6

All these boilers are equipped as standard with the DIEMATIC Evolution control panel.

The DIEMATIC Evolution control panel can be used with various options to manage complex installations, integrate in existing systems and control and regulate a domestic hot water circuit and direct or mixing valve circuits. For larger installations, it is possible to connect 2 to 8 C 230 EVO boilers in cascade configuration.

Various air/flue gas connection configurations are possible. We offer different type of flue systems via horizontal or vertical terminals or connection to a chimney.

OVERVIEW

C 230 EVO boilers are floor-standing condensing gas boilers which are delivered assembled and factory tested.

ENHANCED PERFORMANCE

- Annual operating efficiency > 109 %,
- Low pollutant emissions:
 - NOx < 50 mg/kWh
 - NOx class 6, in line with EN 15502 -1
- Low sound level and power consumption thanks to the modulating fan:
 - 59 dB[A] average sound level at a distance of 1 m from the boiler
 - power consumption from 6 to 306 W (depending on output)

ADVANTAGES OF THESE BOILERS

- They are particularly compact (only 0.54 m² on footprint, and 200 kg for 217 kW).
- Exchanger in cast aluminium/silicium sections offering high corrosion resistance, self-cleaning properties and with no need for a minimum irrigation flow rate thanks to the burner modulation control device which manages the transition phases in the installation that can cause very low or absent flow rates in the boiler
- Cylindrical gas burner with metal fibre coating, modulating from 20 to 100 % with total premix for:
 - perfectly adapts the boiler output to the installation's real requirements
 - optimal combustion quality across the entire output range thanks to the constant air/gas ratio maintained by the venturi system
- Electronic ignition
- Ionisation sensor
- DIEMATIC Evolution control panel with control capability for all installation types, including the most complex: cascade operation possible from 2 to 8 C 230 EVO boilers.
- Numerous control panel configurations enabling management of external safety components, modulating pumps, systems with associated solar functions or heat pumps and programmed control of heating circuits with mixing valves
- It is designed to communicate with the DIEMATIC VM Evolution control systems and remote control systems compatible with ModBus protocol
- Optional 2nd return pipe for maximum exploitation of condensation
- Easy set-up
- Boiler assembled and factory tested
- Easy maintenance:
 - Self-cleaning condensing heat exchanger
 - Rapid access to the burner and all components thanks to the fully removable casing
 - Rapid access to the exchanger surfaces via the inspection hatch.

MODELS

C 230 EVO BOILERS

BOILER

PROJECT



C230_EVO_00003

For heating only, DHW production via independent tank.

CONTROL PANEL DIEMATIC EVOLUTION



DESCRIPTION	REFERENCE	OUTPUT RANGE AT 50/30 °C (KW)
C 230 EVO-85	7823369	20 to 93
C 230 EVO-130	7821715	24 to 129
C 230 EVO-170	7821499	33 to 179
C 230 EVO-210	7826849	44 to 217

DIMENSIONS (mm and inches)

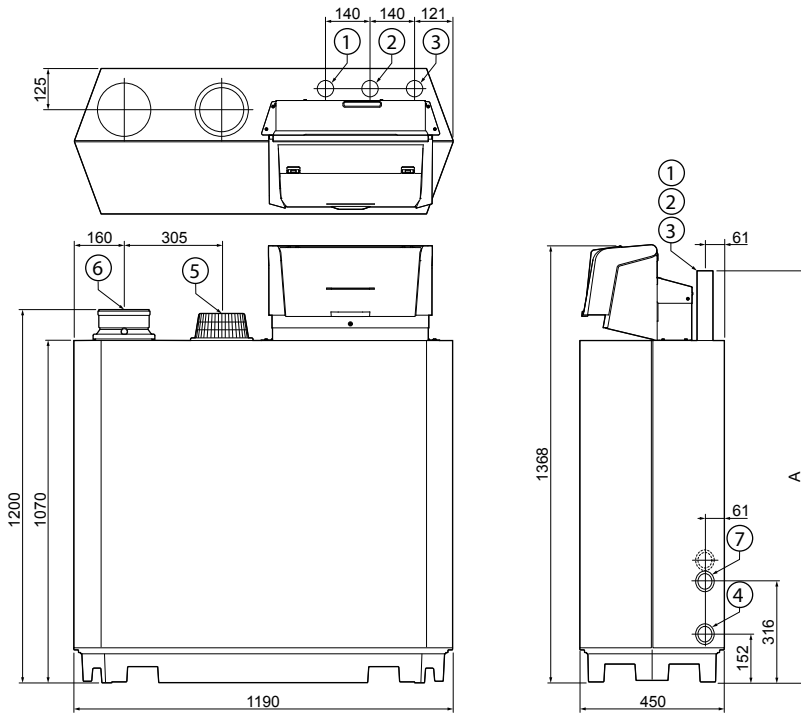

C230_EVO_00110

KEY

	C230 Evo	85 130 170	210
①	Heating circuit flow	1 1/4" male tapping	1 1/2" male tapping (1)
②	Heating circuit return	1 1/4" male tapping	1 1/2" male tapping (1)
③	Gas connection	1 1/4" male tapping	1 1/4" male tapping
④	Condensate drain	external Ø 32 mm	external Ø 32 mm
⑤	Air inlet	Ø 150 mm	Ø 150 mm
⑥	Flue gas outlet	Ø 150 mm	Ø 150 mm
A	Height - gas connection	1309 mm	1324 mm ⁽²⁾
A	Height - gas connection	1309 mm	1309 mm
⑦	Second return (option)	1 1/4" male tapping	1 1/4" male tapping

(1) Affix the 1 1/4" to 1 1/2" reduction piece provided.
 (2) With 1 1/4" to 1 1/2" reduction pieces.

TECHNICAL SPECIFICATIONS

C 230 EVO BOILERS

TECHNICAL SPECIFICATIONS AND PERFORMANCE

Type of generator: heating

Boiler type: condensing

Burner: modulating total premix burner

Energy used: natural gas or propane

Combustion evacuation:

• chimney or forced flue

NOx class: 6

Ref. "CE certificate": PIN 0063DO3332

Average operating temp.:

• Max. operating T: 90 °C

• Min. operating T: 20 °C

FEATURES

MODELS	C 230 EVO					
	85	130	170	210		
Production of useful heat at nominal thermal output and high T° regime (P4) (*)	kW	87	115	166	200	
Production of useful heat at 30% of nominal thermal output and low T° regime (P1) (**)	kW	29.1	38.3	55.2	66.6	
Max. nominal output at 50/30°C (Pnc)	kW	93	129	179	217	
Efficiency in % LCV, load... % Pn and water temp...°C	• 100 % Pn, average temp. 70 °C (RPn) (I)	%	97.4	97.5	97.5	97.6
	• 30% Pn at return temp. 30 °C (RPint) (I)	%	108.6	108.1	108.3	108.4
	• 100 % Pn, at return temp. of 30 °C	%	104.3	104.7	105.2	105.7
Useful energy efficiency at nominal thermal output and high T° regime (Eta 4) (*)	%	87.7	87.8	87.8	87.8	
Useful energy efficiency at 30% of nominal thermal output and low T° regime (Eta 1) (**)	%	97.7	97.5	97.3	97.6	
Nominal water flow rate at Δt 20 K = 11 K	m³/h	6.8	9.4	13	15.6	
Stand-by losses at Δt 30 K	W	230	257	276	288	
Auxiliary electricity consumption at full load (elmax)	W	103	167	196	306	
Auxiliary electricity consumption at partial load (elmin)	W	26	28	46	48	
Auxiliary electricity consumption in standby mode (Psg)	W	6	6	6	6	
Water side pressure drop at ΔT 20 K		mbar	165	135	170	180
	• natural gas H	m³/h	9.4	13.0	18.0	21.7
Max. gas consumption	• natural gas L	m³/h	11.0	15.1	20.9	25.2
	• propane	m³/h	3.6	4.8	7	8.4
Nitrogen oxide (NOx) emissions	mg/kWh	56	49	44	52	
Average sound level at a distance of 1 m (LpA)	dB(A)	59	59	59	59	
Average sound level (LwA)	dB(A)	67	67	67	67	
Flue gas mass flow rate	kg/h	150	197	287	345	
Flue gas min./max. temperature at 40/30 °C	°C	30/63	30/64	30/62	30/64	
Pressure available at boiler outlet	Pa	130	130	130	130	
Water content	l	12	16	20	24	
Footprint	m²	0.54	0.54	0.54	0.54	
Empty weight (without packaging)	kg	115	135	165	188	

(I) Certified value

(*) High temperature regime refers to a return temperature of 60° at the inlet of the heater and a supply temperature of 80 C at the heater outlet.

(**) Low temperature refers to a return temperature of 30° for condensing boilers (at the heater inlet).

TECHNICAL SPECIFICATIONS

C 230 EVO BOILERS

DESCRIPTION

C 230 EVO

DIEMATIC Evolution control panel
ON/OFF button

Air inlet

Flue gas outlet

O₂/CO₂ measuring point

Exchanger in cast aluminium/
silicium sections

Heating exchanger
inspection hatch

Base frame with condensates
collector

Display cover

Service connector

Flue gas pressure switch

Heating flow temperature sensor

Air/gas mixing tube

Fan

Venturi

Gas multibloc

Ignition electrode
and ionisation sensor

Pressure sensor

Combustion air inlet
with silencer

Heating return
temperature sensor

Condensate drain,
siphon (provided)

C230_Q0012

HEAT EXCHANGER C 230 EVO WITHOUT INSPECTION HATCH

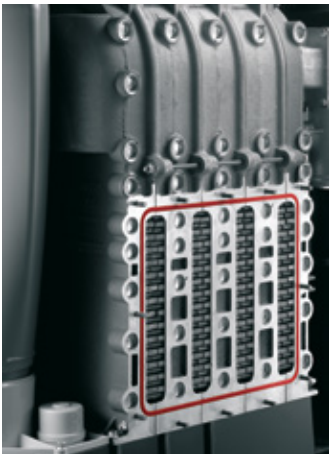

GAS TRAIN C 230 - 170 AND 210 EVO

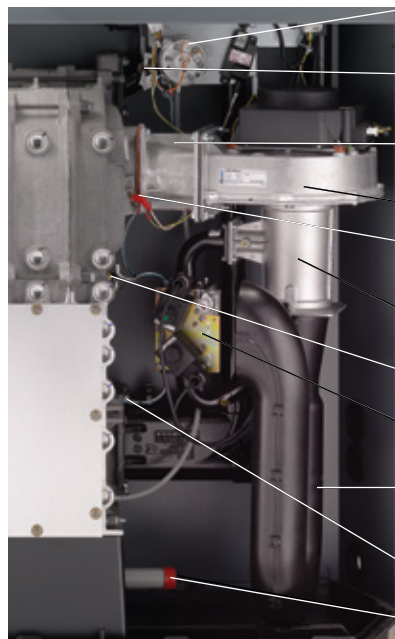

Flue gas pressure switch

Heating flow
temperature sensor

Air/gas mixing tube

Fan

Ignition electrode and
ionisation sensor

Venturi

Boiler sensor

Gas multibloc

Combustion air inlet
with silencer

Heating return
temperature sensor

Condensate drain,
siphon (provided)

C230_Q0010
C230_Q0013

CONTROL PANEL

C 230 EVO BOILERS

INSTALLATION WITH 1 BOILER



C 230... EVO



DIEMATIC Evolution

SECONDARY CIRCUITS THAT CAN BE CONNECTED

• For controlling one circuit:

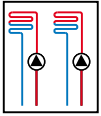

2 x direct

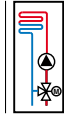

valve

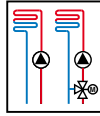

direct
+ 1 valve

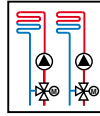

2 x valve

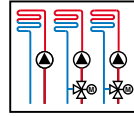

direct
+ 2 x with valve

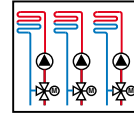

3 x with valve

OPTIONS

standard

1 sensor
AD199



1 sensor
AD199



2 sensors
AD199



1 sensor
AD199



+ 1 AD249
PCB



2 sensors
AD199



+ 1 AD249
PCB



OPTIONS ADDITIONAL

SCB-09 PCB
Connection of
an external gas valve

CASCADE INSTALLATION OF C 230 EVO BOILERS WITH 0-10 V CONTROL

FOR INSTALLATION WITH AN EXTERNAL CONTROL CABINET



C 230 EVO-...



C 230 EVO-...



C 230 EVO-...

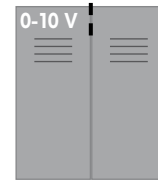

SECONDARY CIRCUITS THAT CAN BE CONNECTED

The boiler room cabinet will manage all the secondary circuits installed.

0-10 V input directly integrated in the boiler as standard.
Option to configure 3 dry signalling contacts

CONTROL PANEL

C 230 EVO BOILERS

CASCADE INSTALLATION OF 2 TO 8 C 230 EVO BOILERS

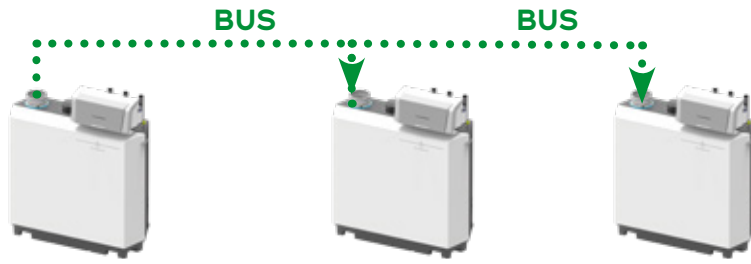

C 230-... EVO

C 230-... EVO

C 230-... EVO

C230_EVO_00003

SECONDARY CIRCUITS THAT CAN BE CONNECTED PER BOILER

• For control system:

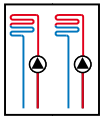

2 x direct

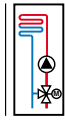

valve

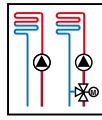

direct
+ 1 valve

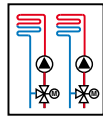

2 x valve

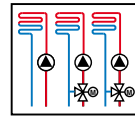

direct
+ 2 x with valve

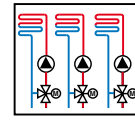

3 x with valve

OPTIONS

original

1 sensor
AD199



1 sensor
AD199



2 sensors
AD199



1 sensor
AD199



+ 1 AD249
PCB



2 sensors
AD199



+ 1 AD249
PCB



OPTIONS ADDITIONAL*

Per boiler:

SCB-13 PCB
For controlling isolation valves
Ref. 7750338

SCB-09 PCB
Connection of
an external gas valve
Ref. 7663076

S-BUS cable
For communication between boilers
AD309 and AD310

AD199 or AD250
cascade flow rate sensor

* Additional functions are possible thanks to these options, see next page.

(1) If more than one direct circuit and two circuits with a mixing valve need to be connected, they can be installed on the slave boilers with a DIEMATIC Evolution control panel.

NOTE: remember to order the "cascade flow sensor", package AD250 or AD199 and BUS cable AD308.

ADDITIONAL FUNCTIONS

OF THE DIEMATIC EVOLUTION CONTROL PANEL

The matrix below shows the additional functions available for each control panel, with the various options.

DESCRIPTION OF ADDITIONAL FUNCTIONS		AVAILABILITY
0 - 10 V configurable input (1)		X
0 - 10 V configurable output (1)	• modulating boiler pump control in 0 -10 V mode	X
	• PWM modulating boiler pump control	X
ON/OFF signal report (1)		X
Alarm (1)		X
Hydraulic isolation valve testing: used to isolate an inactive boiler in cascade configuration to prevent heat loss		SCB-13
Gas pressure switch (1) testing		X
Water pressure switch (1) testing		X
Gas valve leak-tightness testing		SCB-09
Outdoor temperature sensor (1) connection		X

(1) Functions available as standard with the DIEMATIC Evolution control panel

CONTROL PANEL

C 230 EVO BOILERS

PRESENTATION OF THE DIEMATIC EVOLUTION CONTROL PANEL

The **DIEMATIC Evolution** control panel is a highly advanced panel with new ergonomic controls, with a built-in programmable electronic control system as standard which adapts the boiler temperature by acting on the **modulating burner**, based on the outdoor temperature and possibly the room temperature if an interactive remote control is connected.

As standard, the DIEMATIC Evolution is able to automatically control a central heating installation with a direct circuit without mixing valve and 1 circuit with mixing valve (please note: the flow sensor - package AD199 - must be ordered separately).

This means that up to three circuits can be controlled by connecting another "PCB + sensor for 1 valve circuit" (package AD249).

Connecting a domestic hot water sensor can be used to program and regulate a DHW circuit (package AD212 - option).

This control system has been specifically developed to enable **optimal management of systems combining different heating generators** (boiler + heat pump or + solar system, etc.). It allows the installer to configure the entire heating installation, no matter how complex.

Pictograms with info on the installation (circuit temperature, outside air temperature, circuits, etc.)

Date and time

Button to go back to the previous level or menu

On/Off button

Button for the main display

Status indicator LED:

- steady green = normal operation
- flashing green = warning
- red = blockage
- steady red = lockout

Dialogue and information fields

Current menu display

Socket for the PC connection

Rotary/push button:

- turn to select a menu or parameter
- press to confirm the selection

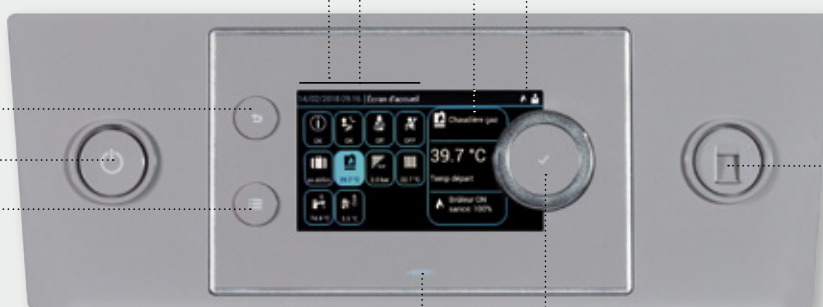

DIEMATIC EVOLUTION CONTROL PANEL OPTIONS



DOMESTIC HOT WATER SENSOR - PACKAGE AD212

It enables regulation with temperature priority and programming of DHW production via a separate tank.



FLOW SENSOR DOWNSTREAM OF VALVE (LENGTH 2.5 M) - PACKAGE AD199

This sensor is necessary for connecting the first circuit with mixing valve to a boiler equipped with the DIEMATIC EVOLUTION control panel.



SENSOR FOR BUFFER TANK - PACKAGE AD250

Comprises 1 sensor for managing a buffer tank with a boiler equipped with a DIEMATIC Evolution control panel.



PCB + SENSOR FOR 1 MIXING VALVE - PACKAGE AD249

It is used to control a mixing valve with an electromechanical or electrothermal motor. The PCB is inserted in the DIEMATIC Evolution panel and is connected using plug-in connectors. The DIEMATIC Evolution can house 1 "PCB + sensor" option, enabling it to control 1 additional mixing valve.

DIEMATIC EVOLUTION CONTROL PANEL OPTIONS



VM_E_Q0009

CONTROL SYSTEM (WALL-MOUNTED) DIEMATIC VM EVOLUTION - PACKAGE AD315

The VM DIEMATIC Evolution electronic control system, built into a wall unit, is used to control and regulate 3 heating circuits and 2 DHW circuits; each of the heating circuits can be a direct circuit or a circuit with a 3-way motorised mixing valve. This enables multiple combinations for any type of installation:

- The DIEMATIC VM Evolution can be used in conjunction with an existing generator to control additional heating and DHW circuits.
- The DIEMATIC VM Evolution can also be used on its own in standalone mode to regulate the heating and DHW circuits depending on the outdoor temperature (sensor to be ordered separately – package FM46), independently of the generator.
- The DIEMATIC VM Evolution can control a boiler via OpenTherm (existing outlet on the VM Evolution) for a boiler equipped with an OpenTherm BUS, or in "ON/OFF" mode via the auxiliary contact for all other generators (burner, heat pump, wood boiler, etc.).
- The DIEMATIC VM Evolution can control a cascade of boilers:
 - equipped with a DIEMATIC control panel
 - equipped with an OpenTherm BUS (an interface PCB maybe required depending on the type of boiler).



REG_Q0003

GTW08 L-BUS-MODBUS GATEWAY - PACKAGE AD332 - REF. 7721982

Many programmable boiler room machine networks use the Modbus as communication protocol for Centralised Technical Management. Despite being a non-proprietary protocol, the Modbus has parameters that may differ from one application to another. This is why our communication gateways that transform our proprietary buses into standard ModBus RTU RS485 have adjustable parameters such as speed, parity and stop bit.



IMG_20230329_16525977

GTW21 L-BUS-BACNET GATEWAY - REF. 7756023

This gateway is for connecting the appliance to a building management system via BACnet over Ethernet. It gives the ability to monitor and manage (control) the appliance and the connected zones.



MCA_Q0152 + MCA_Q01149 + MCA_Q01150 + MCA_Q0151

S-BUS CABLE WITH PLUGS, 1.5 M - PACKAGE AD308 - REF. 7663618

S-BUS CABLE WITH PLUGS, 12 M - PACKAGE AD309 - REF. 7663561

S-BUS CABLE WITH PLUGS, 20 M - PACKAGE AD310 - REF. 7663619

BUS TERMINAL - PACKAGE AD321 - REF. 7688305

The BUS cable enables two boilers equipped with the DIEMATIC Evolution panel to be connected as part of a cascade installation.



SCB_Q0002

SCB-09 PCB - REF. 7663076

PCB with pressure switch connection and gas valve tightness controller. Connection of an external gas valve. This PCB has to be mounted in the control panel.



SCB_Q0001

SCB-13 PCB - REF. 7750338

Control system PCB for controlling a hydraulic isolation valve for cascade installations. This PCB has to be mounted in the control panel.



TH_Q0001/8901Q003

ROOM THERMOSTAT:

• WIRED PROGRAMMABLE – PACKAGE AD337

• NON-PROGRAMMABLE – PACKAGE AD140

These programmable thermostats can be used for weekly programming and regulation of the heating according to the various operating modes: "Automatic" depending on the programming, "Permanent" at a set temperature or "Holiday". The wireless version comprises a transmitter module affixed to the wall near the boiler.

The non-programmable thermostat is only used to control the room temperature based on a specific setpoint.

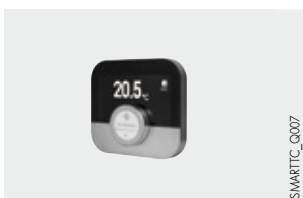

SMARTTC_Q007

SMART TC° WIRED SMART ROOM SENSOR – PACKAGE AD324

Programmable thermostats provide weekly programming and regulation of the heating by activating the burner according to the various operating modes: "Automatic" depending on the programming, "Permanent" at a set temperature or "Holiday". The non-programmable thermostat is used to regulate the room temperature based on the setpoint, by activating the burner. Equipped with a backlit colour screen and a dedicated dropdown menu to simplify use, the Smart TC° is used to control the heating and domestic hot water remotely via an application which can be downloaded free of charge.

OPTIONS

FOR C 230 EVO BOILERS

C 230 EVO BOILER OPTIONS



SECOND RETURN - PACKAGE GR 5 - REFERENCE: 100002442

This is used to differentiate the low and high temperature return circuits in order to make the best use of condensation.
⚠: respect the flow rate distribution.

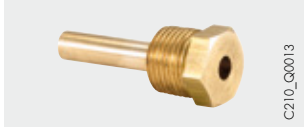

SENSOR POCKET FOR SENSOR - PACKAGE GR 6 - REFERENCE: 100002443

This sensor pocket is supplied for assembly on the heating (plugged when delivered from the factory) and used when connecting an external control system (e.g. boiler room control cabinet).



GAS VALVE LEAK-TIGHTNESS TEST KIT (FOR C 230 EVO-170 AND C 230 EVO-210)

PACKAGE GV 26 - REFERENCE: 100011035

It is adapted to the gas valve and monitors the leak-tightness of the safety valves during pre-sweeping.
If a leak is detected, the boiler will switch to safety mode and the fault will be signalled on the DIEMATIC EVOLUTION control panel.



GAS MINIMUM PRESSURE SWITCH

PACKAGE GV 22 - REFERENCE: 100011031 FOR C 230 EVO-85 AND C 230 EVO-130 PACKAGE GV 25 - REFERENCE: 100011034 FOR C 230 EVO-170 AND C 230 EVO-210

It is adapted to the gas valve and shuts down the boiler if there is insufficient gas supply pressure. The fault will be signalled on the DIEMATIC EVOLUTION control panel.

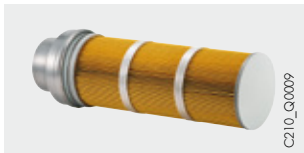

AIR INLET FILTER - PACKAGE GR 8 - REFERENCE: 100002445

This is assembled on the combustion air supply and is used to prevent a loss of output due to fouling of the gas premix burner in dusty atmospheres.



Ø 150 MM MOTORISED FLUE DAMPER - PACKAGE GV 24 - REFERENCE: 100011033

Essential on each boiler in a cascade installation connected to a pressurised duct (B23PI), it is used to prevent the backflow of combustion products towards boilers that have been shut down. This damper is mounted directly on the flue gas outlet. The electrical connection is made via a foolproofed connector on the terminal block of the DIEMATIC EVOLUTION control panel.



80/60 - 1" 1/4 LOW LOSS HEADER FOR C 230 EVO-85

PACKAGE GV 46 - REFERENCE: 100019347

120/80 - 2" LOW LOSS HEADER FOR C 230 EVO-130 TO 210

PACKAGE GV 47 - REFERENCE: 100019348

For any installations with several circuits or for cascade installations, the use of a low-loss header is strongly recommended. The headers are provided with insulation and fitted with a wall-mounting bracket and an accessories kit comprising a plug, an air vent and a 1/2" drain valve.

PROPANE CONVERSION KIT:

- FOR C 230-85 AND C 230-130: PACKAGE GV 23 - REFERENCE: 100011032

- FOR C 230-170 AND C 230-210: PACKAGE GV 27 - REFERENCE: 100011036

The package GV 23 contains a set with diaphragm and gaskets.

The package GV 27 contains a propane gas-unit with venturi.

OPTIONS

FOR C 230 EVO BOILERS

C 230 EVO BOILER OPTIONS



CONDENSATES NEUTRALISATION STATION WITH PUMP:

- FOR C 230 EVO-85 (BOILERS \leq 120 KW) - PACKAGE DU 13 - REFERENCE: 83877009
- FOR C 230 EVO-130 TO 210 (BOILERS \leq 300 KW) - PACKAGE SA 4 - REFERENCE: 7613610
- FOR CASCADE OF C 230 EVO BOILERS UP TO 1300 KW - PACKAGE DU 15 - REFERENCE: 83877011

GRAVITY FLOW CONDENSATES NEUTRALISATION STATION:

- FOR C 230 EVO-85 TO 210 (BOILERS \leq 450 KW) - PACKAGE SA 3 - REFERENCE: 7613609
- FOR CASCADES OF C 230 EVO BOILERS UP TO 1300 KW - DELIVERED IN 3 PACKAGES: (1 X SA 9) + (2 X SA 7) - REFERENCE: 7622256

The condensates neutralisation stations - packages SA4 and SA3 - are delivered with a charge of 25 kg, station ref. 7622256 is delivered with 2 charges of 25 kg and the station in package DU15 with a charge of 10 kg; they are all delivered with their hydraulic and electrical connection accessories for easy adaptation to our boilers.

PRINCIPLE

Acid condensates are conveyed via a reservoir filled with granulates before being sent to the wastewater network. An annual inspection of the system is required, including a check of the effectiveness of the granulates via a pH measurement. The granulates should be replaced if necessary.

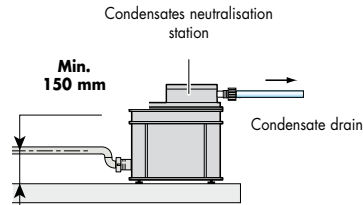

C340_F0200



C330_Q0009

GRANULATE RECHARGE FOR NEUTRALISATION STATION:

- 10 KG - REF. 94225601 (ONLY AVAILABLE FROM THE SPARE PARTS STORE)
- 25 KG - PACKAGE SA7 - REFERENCE: 7613613

An annual inspection of the system is required, including a check of the effectiveness of the granulates via a pH measurement. If necessary, the granulates must be replaced.

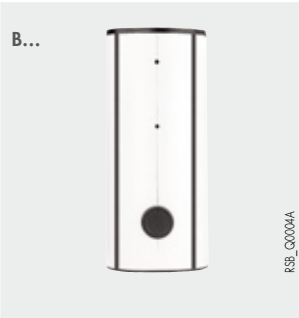

RSB_Q0004A

DOMESTIC HOT WATER PRODUCTION

The De Dietrich independent tanks in the B... series, with a capacity of 150 to 1000 litres, enable production of domestic hot water for individual and collective housing, and for industrial and commercial premises. They have an internal protective layer made from food grade high-quartz vitrified enamel. The specifications and performance of these tanks is given in the price catalogue and respective technical brochures.

INFORMATION REQUIRED

FOR INSTALLATION

REGULATORY GUIDELINES FOR INSTALLATION AND MAINTENANCE

The installation and maintenance of the appliance must be carried out by a qualified professional in compliance with the statutory texts of the codes of practice in force. Low voltage electrical installations. Non-exhaustive list

INFORMATION REQUIRED

FOR INSTALLATION

INSTALLATION IN BOILER ROOM

The dimensions given are the minimum recommended (in m) to ensure sufficient access around the boiler.

Note: for installations with several boilers in cascade configuration, these same dimensions must be observed for each boiler.

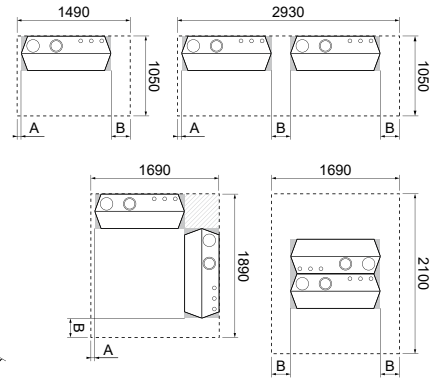
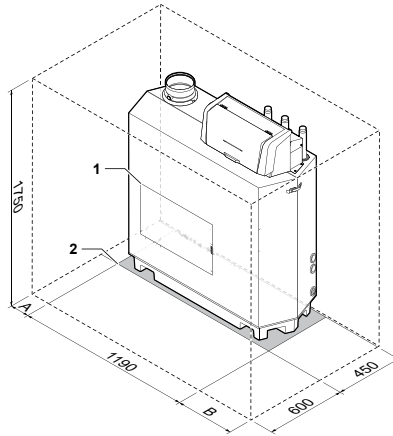

- 1 Location of the heat exchanger inspection cover
- 2 Bearing surface
- A Clearance of 50 mm required to the left of the boiler

- B Clearance of 250 mm required to the right of the boiler

C230_EVO_F0002

Overall dimensions of the boiler for access through doors and corridor:

Boiler type	LENGTH L (MM)	BREADTH B (MM)	HEIGHT A (MM)
C 230 EVO-85	1 190	450	1 309
C 230 EVO-130	1 190	450	1 309
C 230 EVO-170	1 190	450	1 309
C 230 EVO-210	1 190	450	1 324

Minimum access width of doors (T) and corridors (K) required to allow the boiler to be transported (minimum calculated values)

$$K = \frac{B}{T} \times L \quad \text{and} \quad T = \frac{B}{K} \times L$$

Example:
 Calculation of minimum corridor access width (K) required to allow a C 230 EVO boiler to be transported through a door of width
 T = 800 mm:
 K = 450 x 1190 = 670 mm minimum
 800

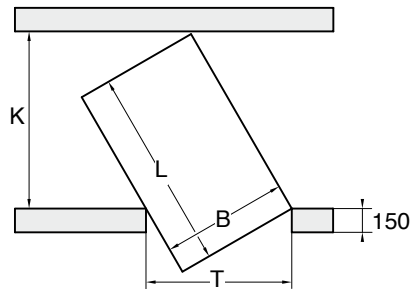

C300 encastrement



In order to avoid damage to the boilers, it is necessary to prevent the contamination of combustion air by chlorine and/or fluorine compounds, which are particularly corrosive. These compounds are present, for example, in aerosol sprays, paints, solvents, cleaning products, washing products, detergents, glues, road grit, etc. The following must therefore be ensured:

- Prevent the intake of air expelled by premises using such products: hairdressing salons, dry cleaners, industrial premises (solvents), premises containing refrigeration systems (risk of refrigerant leakage), etc.
- Avoid storing such products close to boilers.

We would like to underline that, should the boiler and/or peripheral equipment be corroded by chlorine and/or fluorine compounds, the contractual warranty will be invalidated.

INFORMATION REQUIRED

FOR INSTALLATION

ROOM VENTILATION

The cross-section of the boiler room ventilation (through which combusive air is taken in) must comply with the prevailing standard.

GAS CONNECTION

Compliance with prevailing instructions and regulations is mandatory. In all cases, a sectional valve is fitted as close as possible to the boiler. A filter should be fitted to the gas supply inlet immediately after the sectional valve.

The pipe diameters must be defined in accordance with prevailing specifications.

Gas supply pressure: • 20 mbar on natural gas H,

• 25 mbar on natural gas L,

• 300 mbar on natural gas H or L with pressure regulator.

GAS BUFFER TANKS

Gas buffer tanks are one of the solutions used to resolve the issue of accidental triggering of the "min." or "max." pressure switches fitted to gas burners.

Triggering is linked to the inertia of the fluid-expansion system which causes pressure drops and surges in the gas supply line when burners are started up and shut down.

The volume of a buffer tank can be calculated using our software offering, in particular DIEMATOOLS, which can be accessed from our specific website for industry professionals.

INFORMATION REQUIRED

FOR INSTALLATION

ELECTRICAL CONNECTION

This must comply with the prevailing standard.

NOTE

- the sensor cables must be separated from the 230 V circuits by at least 10 cm,
- to help maintain the frost protection and anti-blocking functions of the pumps, we recommend that the boiler is not powered off using the mains switch.
- Depending on the quality of the power supply network, we recommend using an isolation transformer.

HYDRAULIC CONNECTIONS

IMPORTANT

Condensing boilers are based on the principle of recovering the energy contained in the steam from the flue gases (latent heat of vaporisation). As a result, to achieve an annual operating efficiency of around 108%, the heating surfaces must be sized so as to obtain low return temperatures, below the dewpoint (for example, underfloor heating, low temperature radiators, etc.). This must be ensured throughout the heating period.

CONDENSATE DRAIN

The installation must be connected to the wastewater discharge system. The connector must be removable, and the condensate run-off must be visible. The connectors and pipes must be made from corrosion-resistant material. A condensate neutralisation system is available as an option: (see page 12).

CONNECTION TO THE HEATING CIRCUIT

C 230 EVO boilers must only be used in closed circuit heating installations. Before final filling, new installations must be cleaned to remove debris (copper, caulking, soldering flux) resulting from the set-up of the distribution networks and transmitters to prevent any deposits which could lead to malfunctions (noises in the installation, chemical reaction between the metals). If a new boiler is set up in a renovated boiler room, it is strongly recommended that the installation is cleaned/flushed before it is fitted.

It may be necessary to install appropriate filters in some cases.



After such interventions, particular attention must be paid to the quality of the water used to fill the installation to ensure the new boiler can produce the expected performance.

REQUIREMENTS RELATING TO HEATING WATER

HEAT EXCHANGER MATERIAL		ALUMINIUM
HEAT EXCHANGER TYPE		SECTIONS
PROPERTY	UNIT	250 - 1300 KW
Degree of acidity (untreated water)	pH	6.5 - 9.0
Degree of acidity (treated water)	pH	6.5 - 9.0
Conductivity at 25°C	µS/cm	≤ 800
Chlorides	mg/l	≤ 150
Sulphates	mg/l	≤ 50
Other components	mg/l	-
Total water hardness (German degrees)	°dH	≤ 8.4
Total water hardness (French degrees)	°fH	≤ 15.0
Total water hardness (English degrees)	°e	≤ 10.5
CaCO ₃	nmol/l	≤ 1.5

WATER TREATMENT

If, however, it is necessary to have the water treated to ensure it respects the filling water quality requirements, please consult:

- Contact a water treatment specialist who should be able to ensure that the water quality complies with the mix of materials present in the installation, taking all of its components into account.

FLUE GAS CONNECTION

FOR C 230 EVO BOILERS

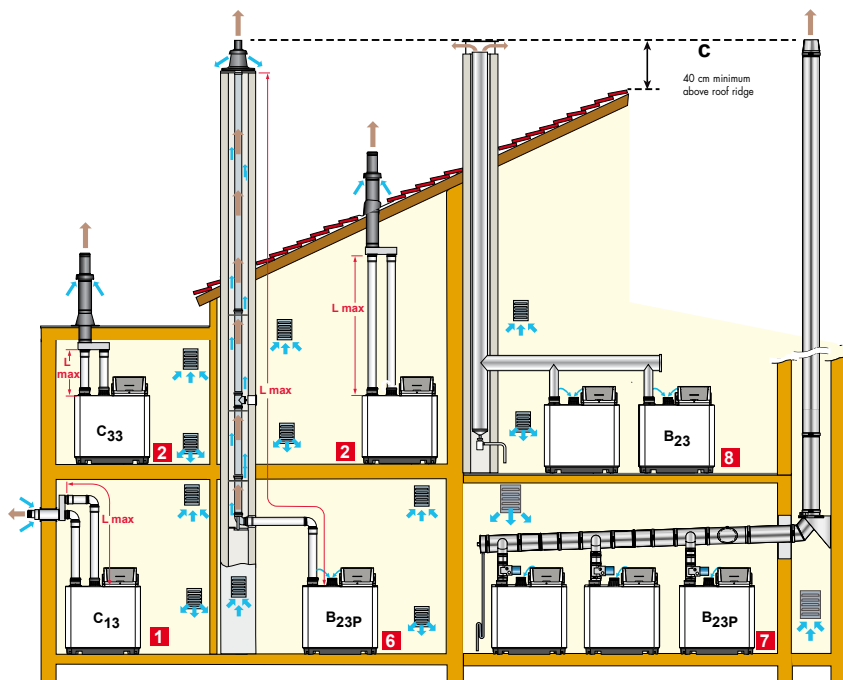

CLASSIFICATION

- 1 CONFIGURATION C13:** Air-flue gas connection via concentric ducts to a horizontal flue terminal ("forced flue").
- 2 CONFIGURATION C33:** Air-flue gas connection via concentric ducts to a vertical terminal (roof outlet).
- 6 CONFIGURATION B23P:** connection to a pressurised flue, with combustion air taken from the boiler room.
- 7 CONFIGURATION B23P:** For cascade installation, combustive air taken from the boilers room. The compulsory flue dampers are to be ordered separately (package gv 24).
- 8 CONFIGURATION B23:** connection of a boiler alone or of boilers in cascade to a moisture-insensitive flue gas conduit under vacuum, the combustive air being drawn from the boiler room.

REMINDER

For type B23 and B23P configurations, mixed use of materials is prohibited.

TABLE OF MAXIMUM PERMISSIBLE AIR-FLUE GAS DUCT LENGTHS BASED ON THE BOILER TYPE

TYPE OF AIR-FLUE GAS CONNECTION		L _{MAX} : MAX LENGTH. CONNECTION DUCT EQUIVALENT IN M FOR C 230 EVO				
		85	130	170	210	
Separate ducts connected to a horizontal concentric flue terminal	C ₁₃	Ø 150 mm (Alu)	50	37	16	14
		Ø 160 mm (PPS)	50	37	16	14
Separate ducts connected to a concentric vertical terminal	C ₃₃	Ø 100 mm	14	4	-	-
		Ø 130 mm	50	38	15	6
		Ø 130 mm ⁽²⁾	60	44	22	8
		Ø 150 mm	60	60	44	24
		Ø 180 mm	60	60	60	60
Separate air and flue gas ducts (combustion air taken from outside)	C ₅₃	Ø 150 mm	60	60	32	19
		Ø 100 mm	19	-	-	-
Chimney (combustion air taken from within the boiler room)	B _{23P}	Ø 110 mm	35	20	8	-
		Ø 130 mm	50	48	22	14
		Ø 150 mm	50	50	45	31
		Ø 180 mm	50	50	50	50

HINWEIS

L_{MAX} measured by adding the lengths of the straight air/flue gas pipes and the equivalent lengths of the other components:

- Ø 150 mm (alu): 1 87° elbow = 6.4 m, 1 45° elbow = 1.7 m, 1 inspection T = 6.4 m, 1 inspection tube = 0.5 m

- Ø 160 mm (PPS): 1 87° elbow = 5 m, 1 45° elbow = 1.4 m, 1 inspection T = 5 m, 1 inspection tube = 0.9 m

FLUE GAS CONNECTION

C 230 EVO BOILERS

6 CONFIGURATION B23p - CHIMNEY

SINGLE BOILER

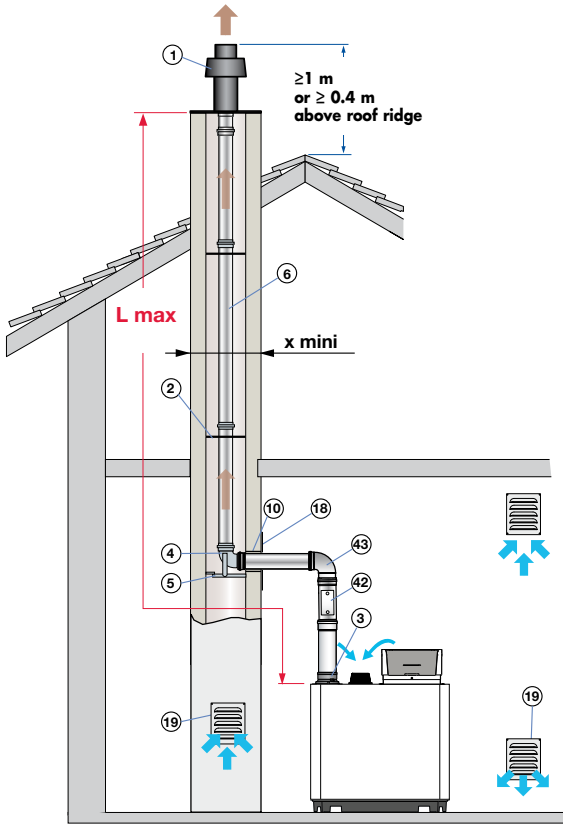

$$x \text{ mini } \begin{array}{l} \square (\text{mm}) : D + 60 \\ \circ (\text{mm}) : D + 80 \end{array}$$

BOILER TYPE	L _{MAX} (m)				
	Ø 100 mm	Ø 110 mm	Ø 130 mm	Ø 150 mm	Ø 180 mm
C 230 EVO-85	19 m	35 m	50 m	50 m	50 m ⁽¹⁾
C 230 EVO-130	-	20 m	48 m	50 m	50 m ⁽¹⁾
C 230 EVO-170	-	8 m	22 m	45 m	50 m ⁽¹⁾
C 230 EVO-210	-	-	14 m	31 m	50 m ⁽¹⁾

(1) Respecting the maximum length, 5 additional 90° elbows or 10 45° elbows can be used (indicated for each type of boiler and for each diameter).

FLUE GAS CONNECTION

C 230 EVO BOILERS

7 CONFIGURATION B23P FOR CASCADE INSTALLATION

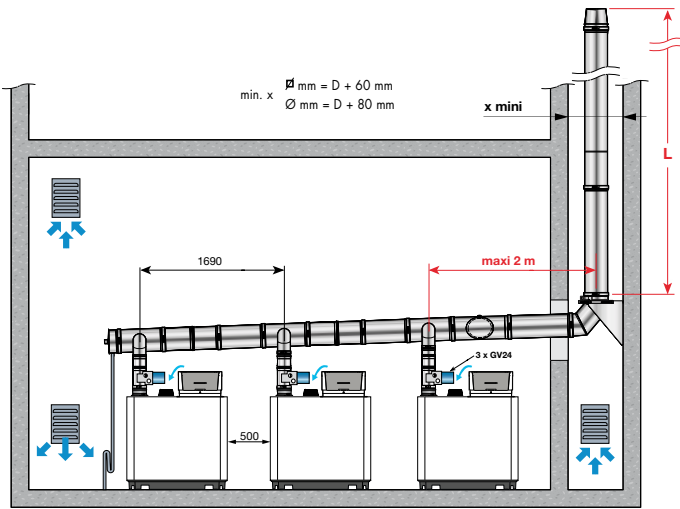

$$x \text{ mini} \begin{array}{|l} \hline \square (\text{mm}) \\ \hline \text{Ø} (\text{mm}) \\ \hline \end{array} \begin{array}{|l} \hline D + 60 \\ \hline D + 80 \\ \hline \end{array}$$

REMINDER
For type B₂₃ and B_{23P} configurations, mixed use of materials is prohibited.

C230_EVO_F0108

MAXIMUM PERMISSIBLE LENGTH L (IN M) BASED ON THE Ø OF PIPE D (IN MM) FOR THE VARIOUS "CASCADE" COMBINATIONS
(These lengths have been defined based on the dimensional constraints given in the diagram above. For different dimensional constraints, please contact us).

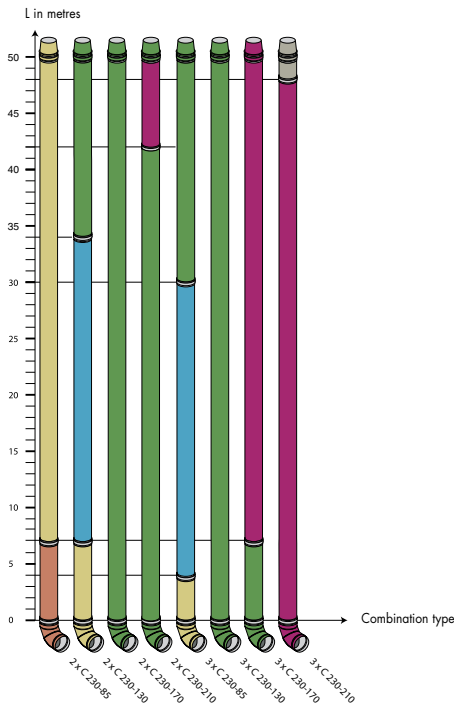

L max as a function of pipe Ø D, for various C 230 "cascade" combinations



- C 230 EVO boilers, 40/30 °C operation
- Isolation damper system to be ordered separately (package GV24)

C230_F100019C

NOTE

These lengths are given as a guide. De Dietrich cannot be held liable in this matter. For different configurations, please contact us to receive a specific calculation.

FLUE GAS CONNECTION

C 230 EVO BOILERS

1 CONFIGURATION C₁₃ - CONCENTRIC HORIZONTAL FORCED FLUE

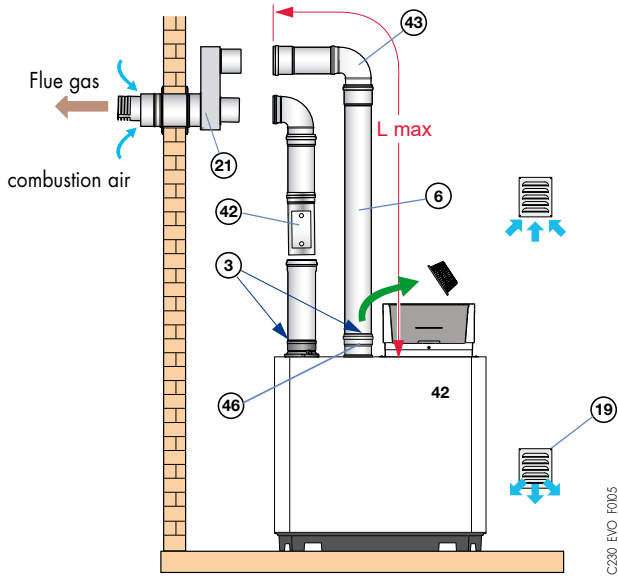

2 CONFIGURATION C₃₃ - CONCENTRIC VERTICAL FORCED FLUE

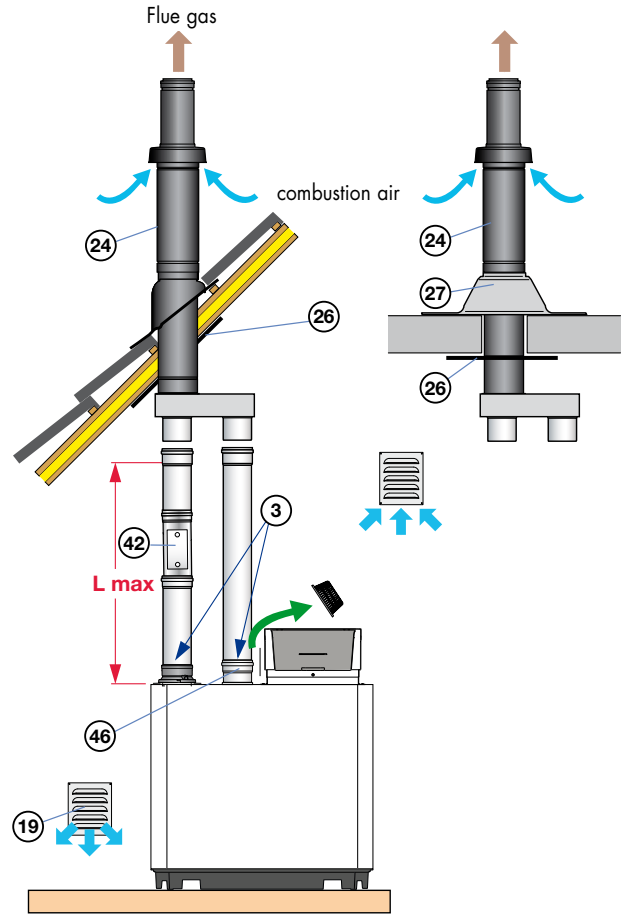

BOILER TYPE

BOILER TYPE	Ø 100 mm	Ø 130 mm	L _{MAX} (m) (1)		
			Ø 130 mm ⁽²⁾	Ø 150 mm	Ø 180 mm ⁽²⁾
C 230 EVO-85	14 m	50 m	60 m	60 m ⁽¹⁾	60 m ⁽¹⁾
C 230 EVO-130	4 m	38 m	44 m	60 m	60 m
C 230 EVO-170	-	15 m	22 m	44 m	60 m
C 230 EVO-210	-	6 m	8 m	24 m	60 m

(1) Respecting the maximum length, 5 additional 90° elbows or 10 45° elbows can be used (indicated for each type of boiler and for each diameter).

(2) With 150/220 mm concentric roof terminal.

INSTALLATION EXAMPLES

The example shown below is intended to draw attention to the basic rules to be respected. A number of safety and control components (including some built into the boilers as standard) are shown, though ultimate responsibility for providing the final safety and control components in the boiler room, based on its individual requirements, lies with the installers, consultant engineers and design offices. In every case, it is important to comply with the applicable regulations and adhere to good industrial practice.

NB: When connecting on the domestic hot water side, if the distribution pipes are made from copper, a sleeve made from steel, cast iron or any other insulating material must be placed between the hot water outlet and these pipes in order to prevent any corrosion phenomena on the connections.

INSTALLATION EXAMPLE

INSTALLATION OF A C 230 EVO DIEMATIC EVOLUTION

- . 1 direct circuit
- . 1 circuit with mixing valve
- . 1 DHW production with separate tank

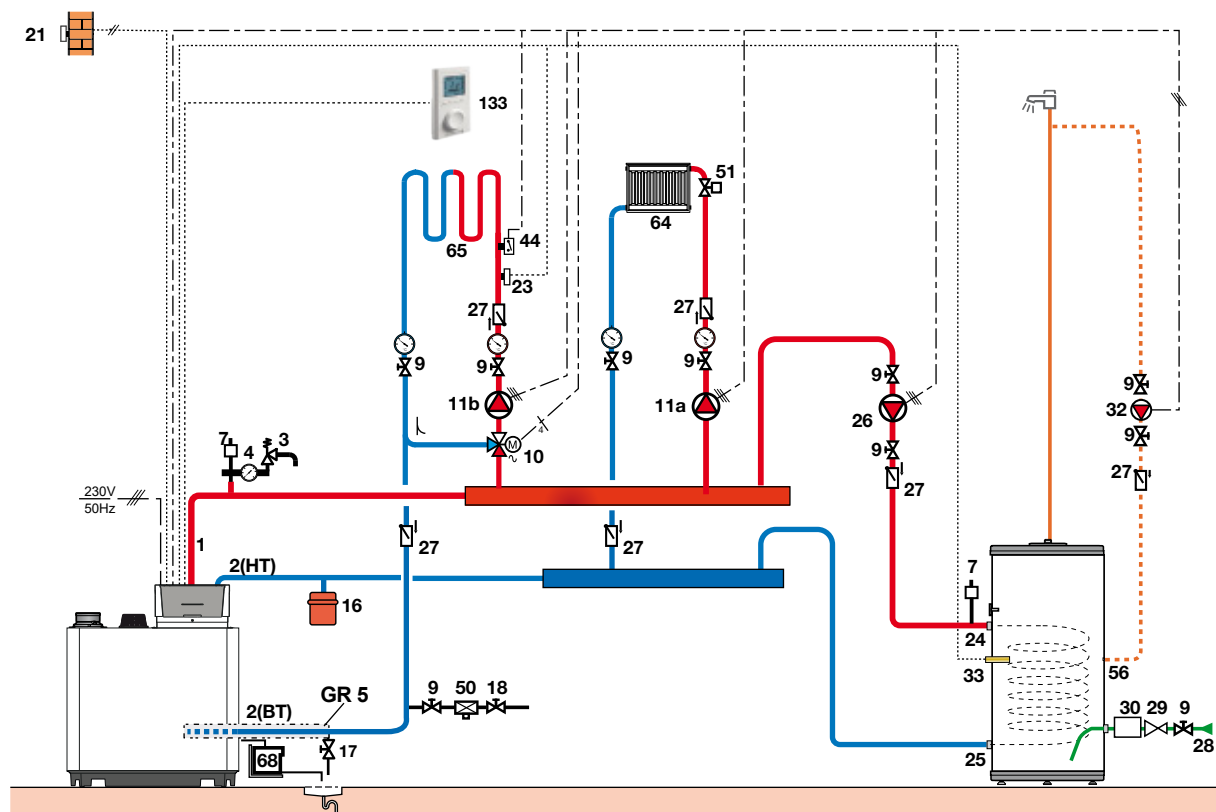

C230_EVO_10109

KEY

- | | | | |
|-----------------------------------|--|--|--|
| 1 Heating flow | 23 Flow temperature sensor downstream of mixing valve (supplied with "package FM48" PCB) | 35 Low-loss header | 68 Condensate neutralisation system (optional) |
| 2 Heating return | 24 DHW tank exchanger primary inlet | 36 Motorised isolation valve with automatic return | 76 Safety pressure relief diaphragm valve calibrated to 6 bar and sealed |
| 3 Safety pressure relief valve | 25 DHW tank exchanger primary outlet | 37 Isolation valve | 115 Thermostatic distribution valve for each zone |
| 4 Pressure gauge | 26 Booster pump | 39 Fuel injection pump | 123 Cascade flow rate sensor (to be connected to the slave boiler) |
| 7 Automatic air vent | 27 Non-return valve | 44 65°C limiter thermostat with manual reset for underfloor heating (DTU 65.8, NFP 52-303-1) | 130 Manual air vent degasser (Airstop) |
| 8 Manual air vent | 28 Domestic cold water inlet | 50 Backflow prevention device | 133 Room thermostat |
| 9 Isolation valve | 29 Pressure reducer | 51 Thermostatic valve | |
| 10 3-way mixing valve | 30 Safety unit calibrated and sealed to 7 bar | 56 DHW circulation loop return | |
| 11 Electronic heating accelerator | 32 Sanitary drain pump (optional) | 61 Thermometer | |
| 12 Sludge settling tank | 33 DHW temperature sensor | 64 Direct circuit (e.g. radiators) | |
| 13 Flush valve | 34 Primary pump | 65 Low temperature circuit (e.g. underfloor heating) | |
| 16 Expansion vessel | | | |
| 17 Drain valve | | | |
| 18 Heating circuit filling | | | |
| 20 Water meter | | | |
| 21 Outdoor temperature sensor | | | |
| 22 Boiler temperature sensor | | | |

C 230 EVO

Floor standing gas condensing boiler, total premix modulating gas burner.

Brand: De Dietrich
Model: C 230 EVO-____ for heating only
Useful output: ____ kW
Used gas: natural gas L - H or propane
Water content: ____ litres
Safety thermostat: 110°C
Gas pressure: 20/25 mbar
Gas flow (natural gas): ____ m³/h
Power supply: 230 V/ 50 Hz
Max. operating temperature: 90°C
Max. operating pressure: 6 bar
Protection index: IP 21
Flue gas pressure available: ____ Pa

Footprint: 450 (L) x 1190 (H) mm
Gas inlet: R 1 1/4"
Ø Flue gas nozzle: 150 mm
Ø Combustion air inlet: 150 mm
Ø Heating flow/return: R 1 1/4"
Ø Condensate draining: 32 mm
Net weight: ____ kg

- Boiler tested in factory
- Control panel Diematic Evolution

DESCRIPTION

- Complies with the requirements of European Directives.
- Classification: B23P - C13 - C53 - C63 - C93
- Operating efficiency up to 109%
- Heat exchanger in cast aluminium-silicium sections highly resistant to corrosion, with self-cleaning properties linked to the flow of condensates requiring no minimum water flow by operating < 75°C
- Cylindrical total premix gas burner with metallic fibre coating. Very low pollutant emissions, NO_x from 44 to 56 mg/kWh (class 1 - EN 297 PrA2)
- Modulating from 18 to 100%
- Perfect adaptation of the boiler output to the actual needs of the installation (between 18 and 100%).
- Low noise level: 59 dB(A) at a distance of 1 m (LpA)
- Electronic ignition
- Condensate drain, siphon provided.
- DIEMATIC Evolution control panel with control capability for all installation types, including the most complex: cascade operation possible from 2 to 8 C 230 EVO boilers.
- Gas categories: I12ESi 3P
- This device complies with the local requested gas category and I2H containing up to 20 % gaseous hydrogen (H2).

Boiler options

- Second return pipe
- Motorised flue damper
- Conversion GPL kit
- Sensor tube for outlet sensor
- Gas valve unit sealing control
- Air intake filter
- Minimum gas pressure switch
- 300 mbar pressure regulator
- Condensates neutralisation system (boilers until 120 kW)
- Condensates neutralisation system (boilers from 120 to 350 kW)
- Condensates neutralisation system (boilers from 350 to 1300 kW)
- Neutralisation granules 10 kg.

Control panel options

- Sensor for mixing valve
- Flue gas temperature sensor
- PCB + sensor for 1 circuit with mixing valve
- PCB + sensor for 1st mixing valve circuit for panel K3
- DVVH sensor
- Interactive remote "radio" control CDR D. iSystem
- Interactive remote control CDI 2
- Simplified remote control with room sensor
- PCB + sensor for mixing valve
- Telemonitoring vocal module
- Bus cable connection 12 m
- Bus cable connection 40 m for wall brack
- Bus cable connection RX 10

De Dietrich 

BDR THERMEA France
S.A.S. With corporate capital of 229 288 696 €
57, rue de la Gare - F - 67580 Mertzwiller
Tel: +33 388 80 27 00 / Fax: +33 388 80 27 99
www.dedietrich-heating.com

